



M MECHAN CONTROLS

Installation Instruction for O-Type Safety Switches

*OHE1 Coded Magnetic and ODNK / OSSG Uniquely Coded RFID with
OSSD Outputs*



www.mechancontrols.com
sales@mechancontrols.co.uk
+44 1695 722 264

Machine Safety for People and Productivity

O-Type Features and Benefits



- OHE1 Coded Magnetic
- ODNK / OSSG Uniquely Coded RFID
- Maintain PL-e when Connected in Series using OSSD Outputs
- Advanced LED Diagnostic Display
- External Device Monitoring (Advanced type)
- 2 Amp Safety Output Rating (Pre-Wired) 1Amp (Quick Disconnect)
- Multiple Operating Angles for Easy Installation (ODNK)
- Meets the Requirements for CAT4 and SIL3

The O-Type range combines 40+ years of experience designing and manufacturing machine guard safety products with the latest in safety technology. Their unique design means 30 O-Type switches can be connected in series maintaining PL-e status.

OHE1	ODNK / OSSG
<p>The OHE1 uses coded magnetic technology that meets the requirements of type 4 coding in accordance with EN ISO 14119. The OHE1 also includes misalignment indication to improved installation.</p>	<p>The ODNK / OSSG has individually coded RFID technology that meets the requirements of type 4 in accordance with EN ISO 14119. Due to the unique design, the switch can be mounted and operated on 4 sides making it incredibly versatile.</p>

O-Type safety switches include two LEDs for indication. They are able to provide visual diagnostics for ALL states of the device. This means the user can easily fault find without needing to access the control panel.

The O-Type safety switches are available with a feature called EDM (external device monitoring, this means the outputs can be used to monitor the state of contactors without the need for a safety control unit.



Designed for Series Connection

The O-Type range features OSSD outputs designed to maintain a high level of functional safety even through series connection.



Overhanging LED Display

Our new LED design means you can see the indication when mounted on multiple faces.

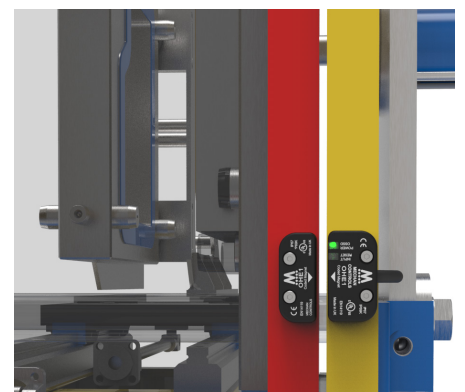

Slim Line Design for Small Guards

The slim line design means the O-Type are suitable for applications with smaller guarding.

Technical Specification

	ODNK / OSSG	OHE1
Technology	RFID	Coded Magnetic
Coding	Individually Coded (4 Billion Codes)	Magnetically Coded (One Generic Code)
Electrical Data of Safety Outputs		
Safety Contact Type	PNP type OSSD	PNP type OSSD
No. of OSSD Inputs (Max)	2	2
No. of OSSD Outputs	2	2
OSSD Pulse Width	400 µs	400 µs
Maximum Current per Output	2 A, max.; Status ON (+24V DC) - Door Closed	2 A, max.; Status ON (+24V DC) - Door Closed
Switching Characteristics	10mm ON / 20mm OFF (Max)	8mm ON / 17mm OFF (Max)
Misalignment Characteristics	A misalignment of +/- 4mm	A misalignment of +/- 4mm
Minimum gap between switch and actuator	2mm	1mm
Short Circuit Detection	YES	YES
Over Current Protection	YES	YES
External Protection Fuse	1.8 A Fast Acting	1.8 A Fast Acting
Electrical Data of Auxiliary Output		
Output Type	PNP	PNP
Maximum Current per Aux Output	2 A, max.; Status ON (+24V DC) - Door Open	2 A, max.; Status ON (+24V DC) - Door Open
Over Current Protection	YES	YES
External Protection Fuse	1.8 A Fast Acting	1.8 A Fast Acting
Power Supply Electrical Data		
Supply Voltage Options	24VDC (+/- 15%)	24VDC (+/- 15%)
Switch Power Consumption (Max)	50mA	50mA
Overvoltage Category	III	III
General Information		
Construction	Yellow ABS	Black ABS
IP Rating	IP67 / IP69K	IP67 / IP69K
Operating Temperature	-10°C to +60°C	-10°C to +60°C
Fixing	4 X M4 Security Screws	4 X M4 Security Screws
Connection	Pre-Wired or M12 QD	Pre-Wired or M12 QD

Safety Related Data			
B10d	10,000000	PFH	1.1 x 10 ⁻⁹
TM (Mission Time)	>100 Years	PFHd	1.12 x 10 ⁻⁹
DC	99%	SFF	99.5%
MTTFd	High > 385 Years (Based on usage rate of 360 Days/Year, 24 Hours/Day, 10 Operations/Hour)		
SIL up to	SIL 3 acc. to EN 62061		
Performance Level (PL) up to	PL-e acc. to EN ISO 13849-1		
Safety Category up to	CAT4 acc. to EN ISO 13849-1		
Coding	ODNK Type 4 acc. to EN ISO 14119 / OHE1 Type 2 acc. to EN ISO 14119		

Safety Standards	
Approvals	CE Complies with all relevant sections of the CE Marking Directive
	TUV Approved (Pending)
	cULus 508 Industrial Control
International Directives	Machinery Directive 2006/42/EC, Low Voltage Directive 2014/35/EU; EMC Directive 2014/30/EU, RoHS Directive 2011/65/EC
International Standards	EN 12100 Safety of Machinery. General principles for design.
	EN ISO 14119 Safety of Machinery. Interlocking devices associated with guards. Principles for design and selection. EN ISO 13849 Safety of Machinery. Safety related parts of control systems.
	EN ISO 62061 Safety of Machinery. Functional safety of safety related electrical, electronic and programmable electronic control systems
	EN 60204 Safety of Machinery. Electrical equipment of machines.
	EN 60947-5-1 Low-voltage switchgear and controlgear. EN 60947-5-3 Low-voltage switchgear and controlgear.

Dimensions

ODNK/OHE1
SWITCH

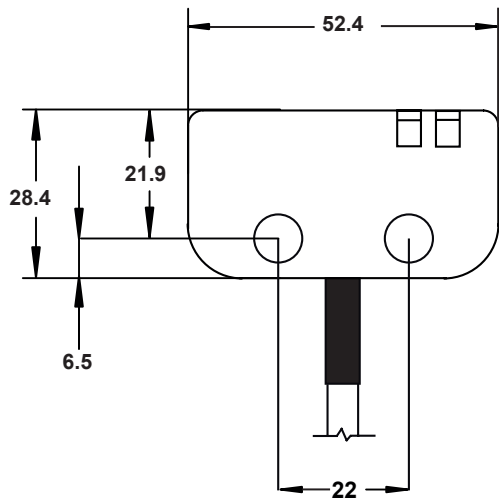

ODNK/OHE1
ACTUATOR

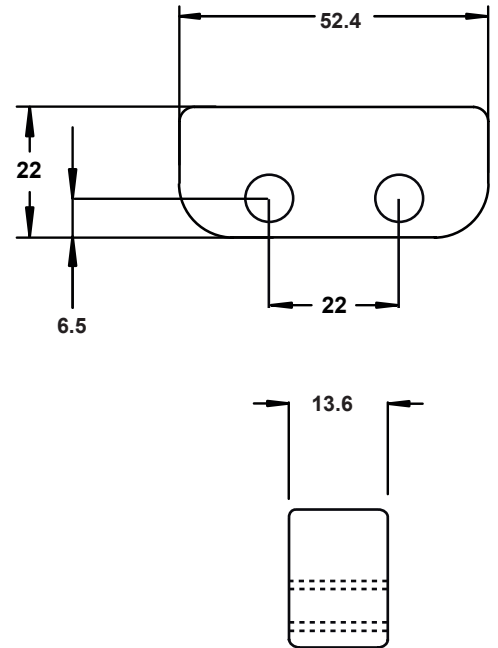

OSSG
SWITCH

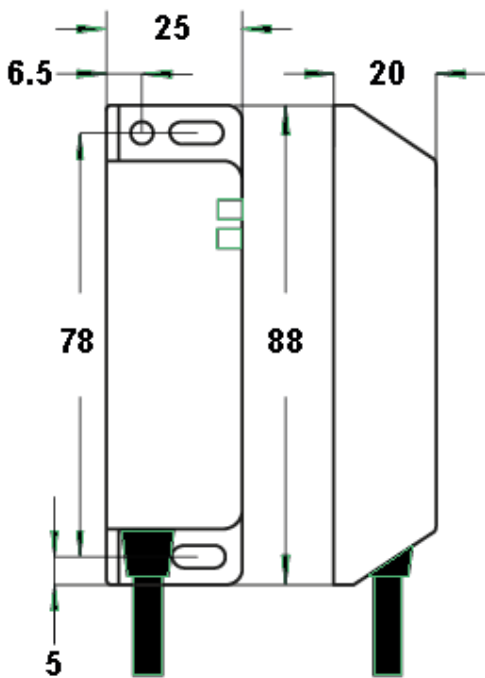

OSSG
ACTUATOR

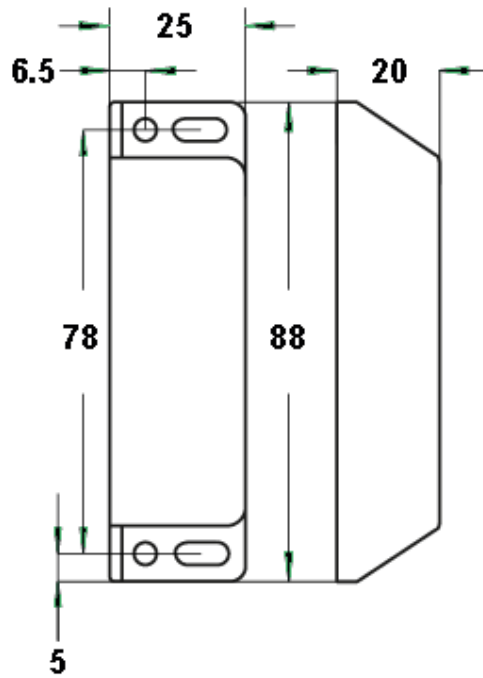

****All dimensions are in MM***

Lateral and Vertical Mounting

Mounting

Do not use safety switches as a stop.

Mount the switch on to the machine frame and the actuator on to the opening edge of the door.

Always try to mount the switch on non-ferrous material. (Ferrous materials may reduce the switching distance.)

NOTES:

Minimum separation 50mm between adjacent switches

DO NOT mount on hinged side of the guard.

Leave a minimum gap of 2mm between the switch and actuator.

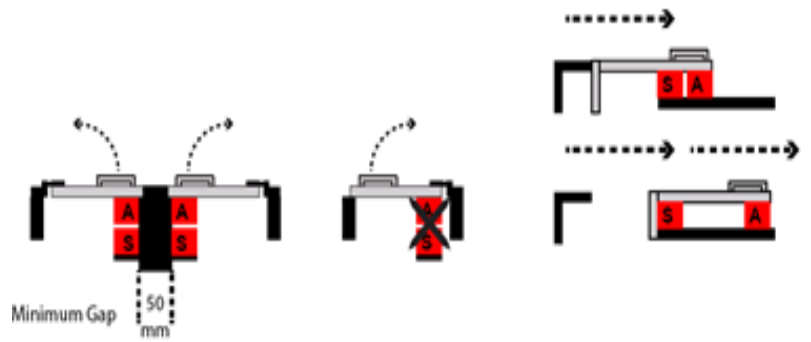

Operating Face and Misalignment

Operating Faces

Designed to operate on **ALL** guard positions. The ODNK and OSSG are extremely versatile.

The ODNK and OSSG will operate on two faces.

Whereas the OHE1 will only operate on the front face.

All O-Series switches have a +/- 4mm misalignment.



ODNK operates on two faces

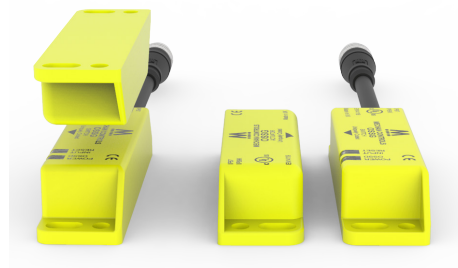

OSSG operates on two faces

Misalignment indication

The OHE1 has a feature that will show the user if the switch is not aligned correctly. All O-Series switches have a +/- 4mm misalignment.



OHE1 operates on one face.

Installing an O-Type Safety Switch

- Drill holes or use a mounting plate to secure the switch and actuator
- Use the security screws provided in the packaging
- It is important that the switch and actuator are correctly alligned (See page 3 and 4)
- **Leave a minimum gap of 2mm between the switch and acuator**

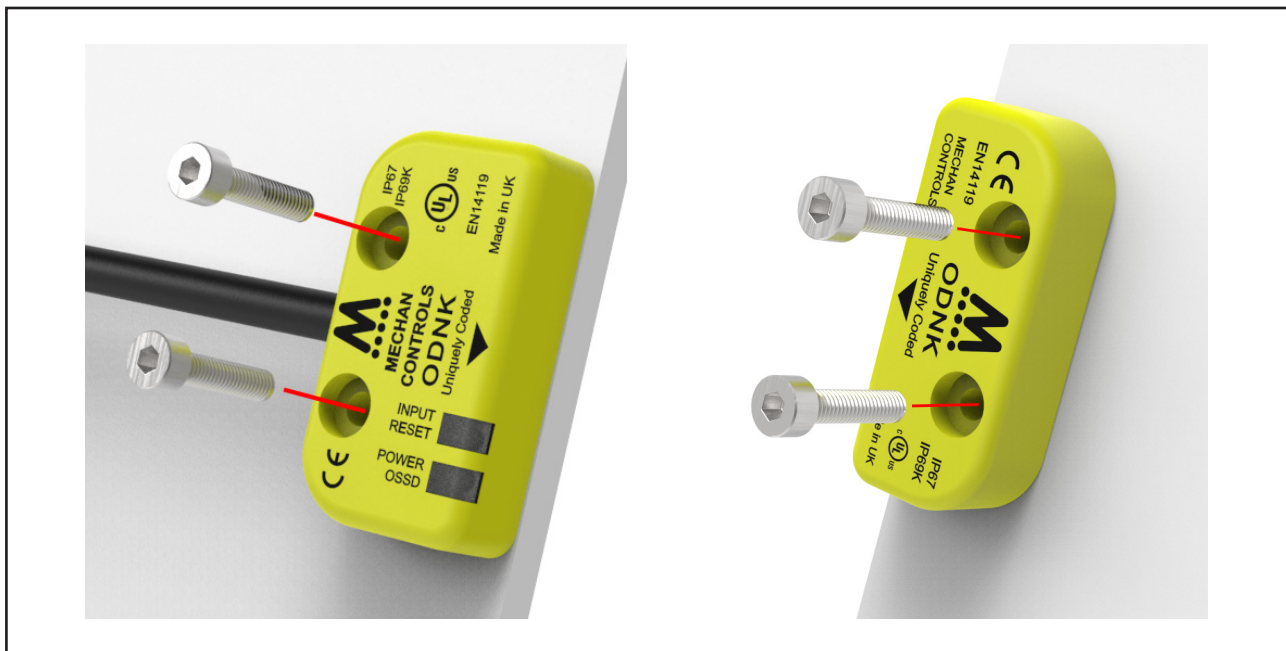

Teach Mode (ODNK / OSSG Only)

If during installation you lose or break the accompanying actuator, it is possible to re-teach a new part by following these steps:

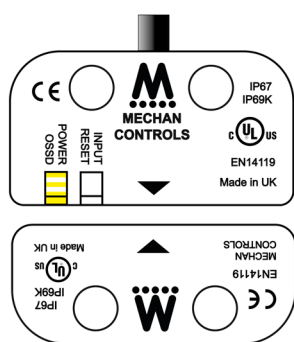

Step 1

Power/OSSD LED Flashing yellow indicates a incorrect coded actuator has been detected.

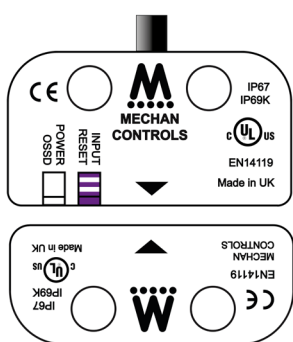

Step 2

Drop the supply to 0v then bring back up to 17v. Input/Reset LED will begin to flash purple meaning it is ready to accept a new code.

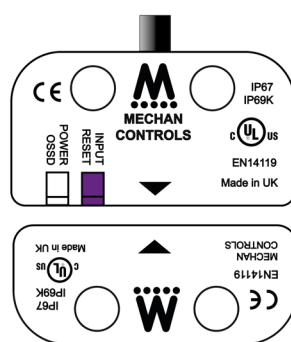

Step 3

Bring the new actuator with-in operating distance of the switch. Input/Reset LED will stop flashing and turn solid purple. This means the new code has been accepted.

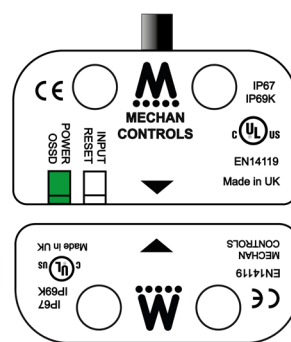

Step 4

Increase the supply to 24Vdc. Input/Reset LED will switch OFF or turn blue (If connected in monitored reset.) and Power/OSSD LED will change to green.

Wiring & Connection

M12 Connections

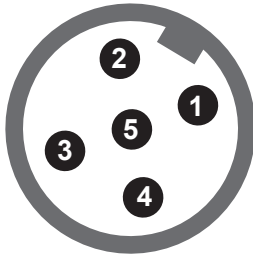

Simple Connection Type
(M12, 5 pins, Male)

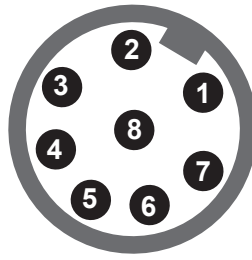

Standard Connection Type
(M12, 8 pins, Male)

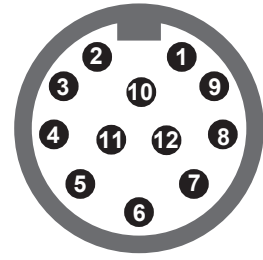

Advanced Connection Type
(M12, 12 pins, Male)

PIN	Function	Wire Colour
1	+24VDC	Brown
2	OSSD 1 Output	Grey
3	0V	Blue
4	OSSD 2 Output	Black
5	Auxiliary	White

PIN	Function	Wire Colour
1	Auxiliary	White
2	+24VDC	Brown
3	NOT USED	Green
4	OSSD 2 Input	Yellow
5	OSSD 1 Output	Grey
6	OSSD 2 Output	Pink
7	0V	Blue
8	OSSD 1 Input	Red

PIN	Function	Wire Colour
1	Auxiliary	White
2	+24Vdc	Brown
3	NOT USED	Green
4	OSSD 2 Input	Yellow
5	OSSD 1 Output	Grey
6	OSSD 2 Output	Pink
7	0V	Blue
8	OSSD 1 Input	Red
9	Reset / EDM Input	Black
10	A / M Select	Violet
11	NOT USED	Grey / Pink
12	NOT USED	Red / Blue

Pre-Wired Connections

Function	Standard	Advanced
+24VDC	Brown	Brown
0V	Blue	Blue
OSSD 1 Output	Grey	Grey
OSSD 2 Output	Pink	Pink
Auxiliary	White	White
OSSD 1 Input	Red	Red
OSSD 2 Input	Yellow	Yellow
A/M Select	Orange (not used)	Orange (see note 1)
Reset / EDM	Green (not used)	Green (see note 1)

Note 1: Advanced Connection

Orange Connect to 0v for automatic reset or +24Vdc for monitored reset. If multiple switches are wired in series, the reset will be controlled by the last connected switch.

Green Connect to a momentary push button if installed in monitored reset configuration or +24Vdc if wired for automatic reset. If multiple switches are wired in series, the reset will be controlled by the last connected switch.

Wiring Example

Series connection for ODNK, OSSG or OHE1 with automatic reset to a safety PLC or Mechan GM1

Maximum Cable Length	30 m
Maximum Number of Connected Units	30

The O-Type can be connected, provided that compatibility is checked, to safety modules or safety PLCs with OSSD inputs.

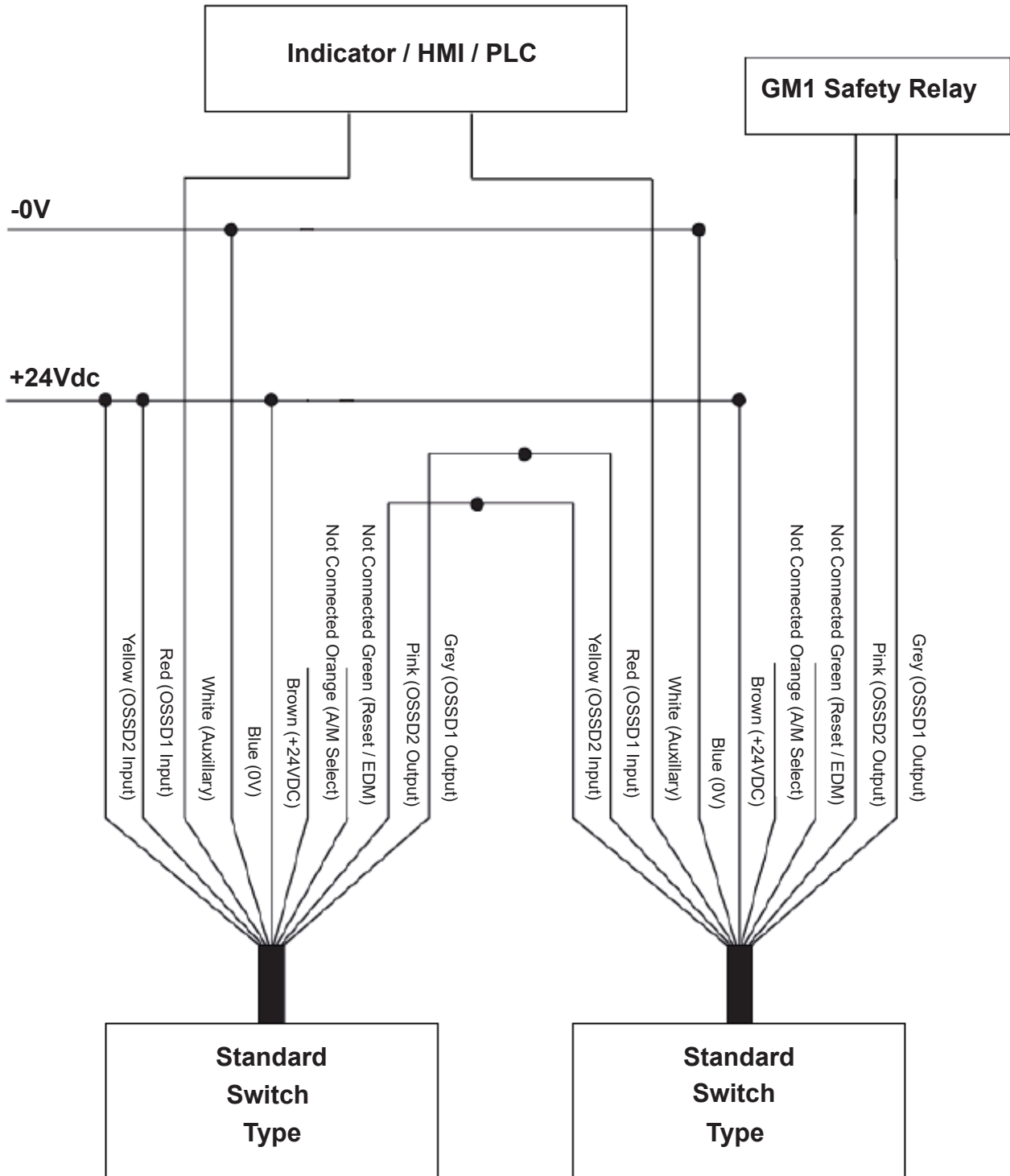

Typical connection example for ODNK, OSSG and OHE1

Wiring Example

Advanced series connection for ODNK, OHE1 and OSSG with EDM connection and cross monitoring

Maximum Cable Length	30 m
Maximum Number of Connected Units	30

The contactors and relays must be force guided in order to safely monitor the external device.

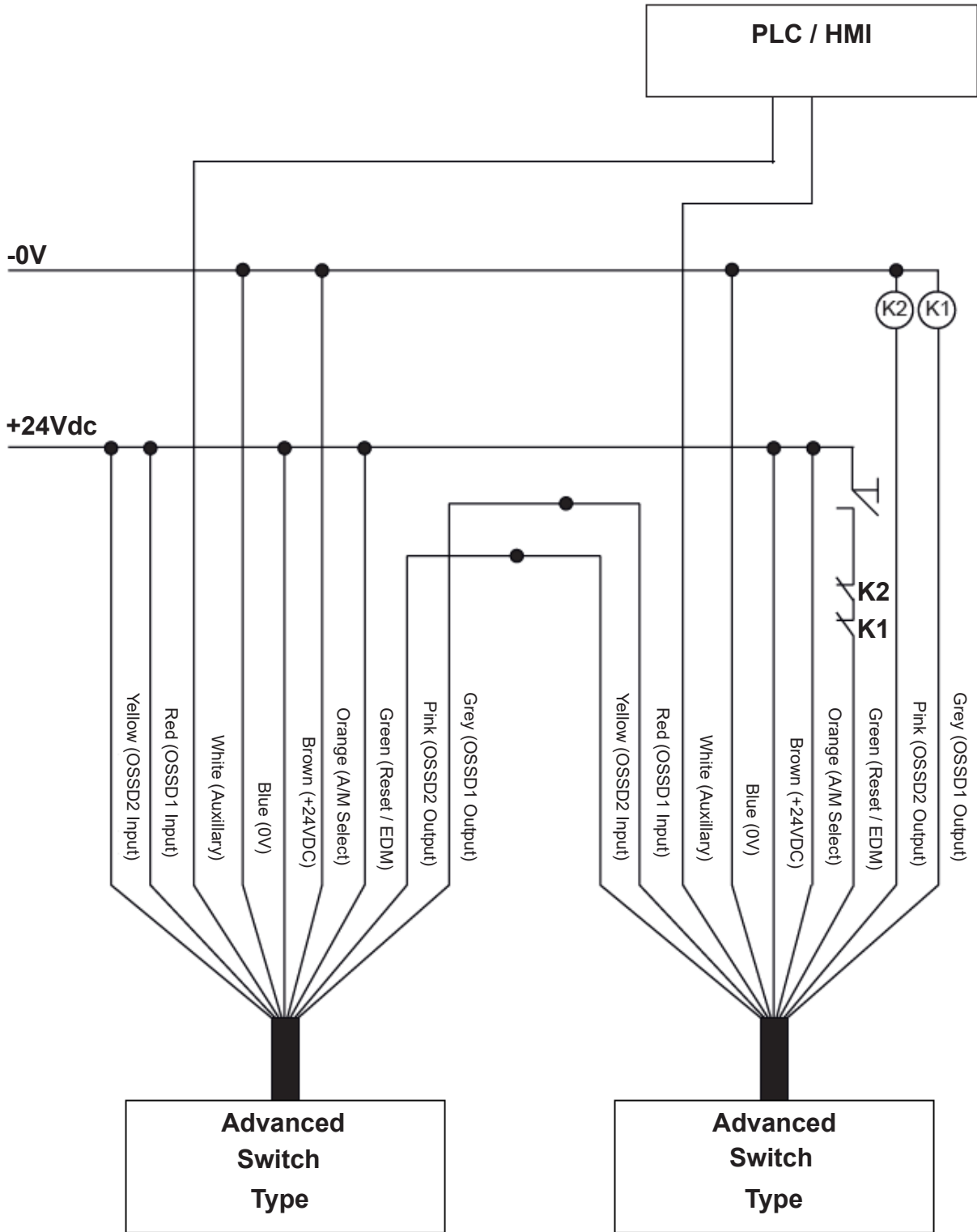

Advanced connection example for ODNK, OHE1 and OSSG with external device monitoring reset (EDM)

Note: The last switch is used to monitor the external device and control the reset function via a push button.

Indication

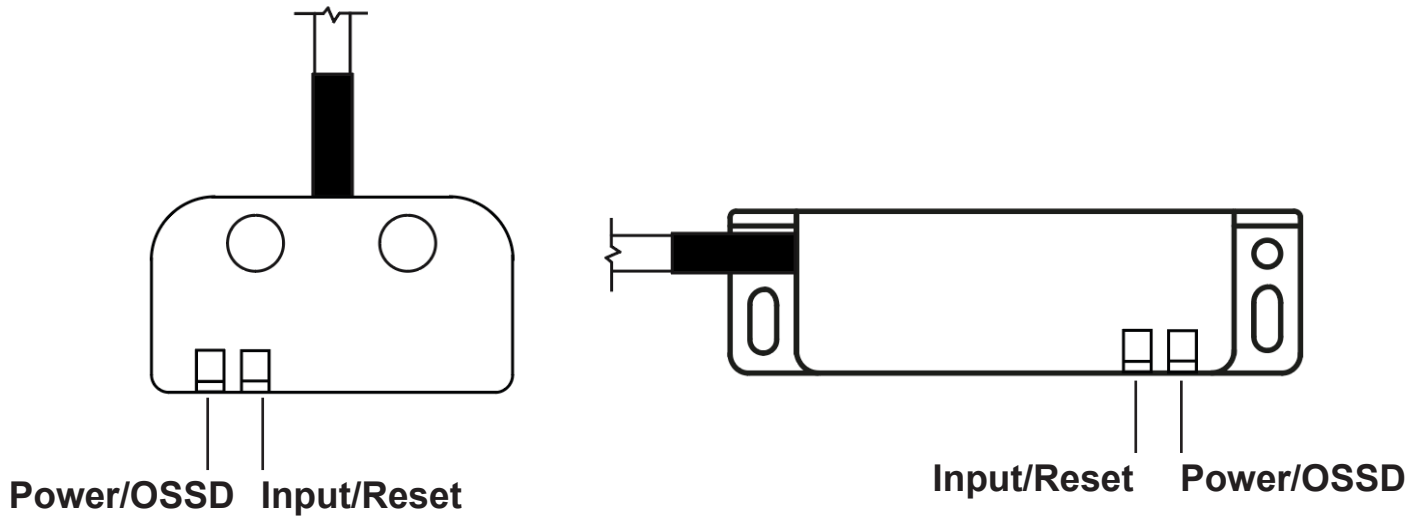

ODNK / OSSG LED Configuration

Power/OSSD LED	Input/Reset LED	Description
		No Power supplied to switch
Solid Red		Power Supplied to switch, no actuator present
Flashing Red		Output fault (turn power off and on to reset)
Flashing Red	Flashing Yellow	OSSD input fault (turn power off and on to reset)
Solid Green		OSSD outputs are present and operating correctly
Flashing Green	Solid Yellow	Actuator present, OSSD inputs not detected
Flashing Green	Solid Blue	Actuator present, OSSD inputs present, external circuit needs resetting (EDM only)
Flashing Yellow		No input, wrong actuator
	Solid Purple	Actuator has been taught
	Flashing Purple	No actuator present, voltage is at 17v ready to be taught

OHE1 LED Configuration

Power/OSSD LED	Input/Reset LED	Description
		No Power supplied to switch
Solid Red		Power Supplied to switch, no actuator present
Flashing Red		Output fault (turn power off and on to reset)
Flashing Red	Flashing Yellow	OSSD input fault (turn power off and on to reset)
Solid Green		OSSD outputs are present and operating correctly
Flashing Green	Solid Yellow	Actuator present, OSSD inputs not detected
Flashing Green	Solid Blue	Actuator present, OSSD inputs present, external circuit needs resetting (EDM only)
Flashing Yellow		Actuator Misaligned to switch

Solid Yellow (Input/Reset LED) Check previous connected safety switch is closed (operating) or check if inputs are connected correctly.

Flashing Yellow (Input/Reset LED) OSSD Input faults are due to different signals, one channel going high and the other low.

****-21-DC-EDM-03M

Version	
OHE1	Coded Magnetic
ODNK	Unique Code RFID
OSSG	

OSSD Safety Channels	
2	2 Outputs

Signalling Output	
1	1 Auxiliary Output

Supply Voltage	
DC	24Vdc

Connection Type	
03M	3 Metre Pre-Wired
06M	6 Metre Pre-Wired
10M	10 Metre Pre-Wired
5LQD	5-Pin M12 150mm Leaded QD
8LQD	8-Pin M12 150mm Leaded QD
12LQD	12-Pin M12 150mm Leaded QD

Function	
EDM	External Device Monitoring

Example 1:

ODNK-21-DC-03M

Small type of O-Type housing

DC Voltage

Has 2 and 1 output contacts

3 Meter cable

Example 2:

OSSG-21-DC-EDM-03M

Large type of O-Type housing

DC Voltage

3 Meter cable

Has 2 and 1 output contacts

External device monitoring

Information

Safety Assessment

A risk assessment should take place to establish that the specifications of these safety switches are suitable for the application required. Please contact Mechan Controls for further information.

The products may only be installed, commissioned, operated, maintained by competent persons.

A competent person is a qualified and knowledgeable person who, because of their training, experience and current professional activity, has the specialist knowledge required. An understanding of European and International laws, directives and standards is recommended.

Maintenance

It is recommended to check the safe operation of the switches and look for signs of damage or excessive wear on a weekly basis. Damaged units should be replaced or returned to the manufacturer for repair where practical.

Disclaimer

In the interest of product development specifications are subject to change without notice. It is the responsibility of the user to ensure compliance with any acts or by-laws in place. All information regarding Mechan equipment is believed to be accurate at the time of printing. Responsibility cannot be accepted for errors or omissions.

Warranty

Warranty will be void if the following points are true:

- The product was not used for its intended purpose
- Damaged was caused by usage not stated in the manual
- Modifications have been made to the products (e.g exchanging components)
- Operating personnel are not suitably qualified
- Product is not fitted correctly according to install guide

Warning!



Removing the actuator from the guard may lead to loss of safety resulting in serious injury or death.

Security screws are provided with every O-Type safety switch.



14/16 Seddon Place Stanley Industrial Estate Skelmersdale Lancashire WN8 8EB
Telephone: +44 (0) 1695 722264 Fax: +44 (0) 1695 729664 Email: sales@mechancontrols.co.uk

www.mechancontrols.com